

K191 – 3 Channel RGB LED Controller

1 Introduction.

This kit has been designed to function as a versatile LED control module. The LED controller provides 3 high current channels to create light effects for the presentations, parties, etc. The module includes preprogrammed light sequences and can be used as a standalone LED controller. The module also supports a serial interface which uses only 2 wires to communicate with your microcontroller or PC. The simple command set allows easy module control from the microcontroller or PC. **The module is ideal for use with flexible LED light strips.**

Key Features

- 3 high current channels with independent control.
- Suitable for common anode RGB LED strips, LEDs and incandescent bulbs.
- 6 preprogrammed light sequences with hard transition effects (running light, Strobo, random colors, etc...) and smooth fade effects (color change, slow on/off, etc...).
- Custom user-editable sequence.
- Wide-range effect speed adjust.
- Memory for last selected sequence and user-editable sequence.
- Serial TTL interface to control from your microcontroller or PC.
- Addressable. Multiple modules can be connected with independent control for each module.
- Windows software to control the module from PC and download the user-editable sequence.
- Small form factor (2.2" x 1.55", 56 x 39 mm).

NOTE: The full expanded version of this documentation can be downloaded from www.kitsrus.com/pdf/k191exp.pdf.

Specifications

Operating Voltage	12VDC (nominal)
Channel Current	5A max, 12A max for all 3 channels
LED PWM frequency	480 Hz
LED intensity control	250 intensity levels/channel
Communication Interface	Serial RS232 and serial TTL interface, 9600 baud, 8 data bits, 1 stop bit, no parity, no handshaking
Dimension	2.2" x 1.55" x 0.5", 56 x 39 x 12 mm

2 Description.

The module includes a microcontroller, 5V voltage regulator and high current MOSFETs. The microcontroller provides PWM control for the MOSFETs, the serial communication interface and includes 6 preprogrammed light effect sequences. Custom light sequences can be downloaded to the microcontroller memory. Press a button to switch the light sequences. The last selected sequence is saved in memory.

2.1 Common anode LED strip connection.

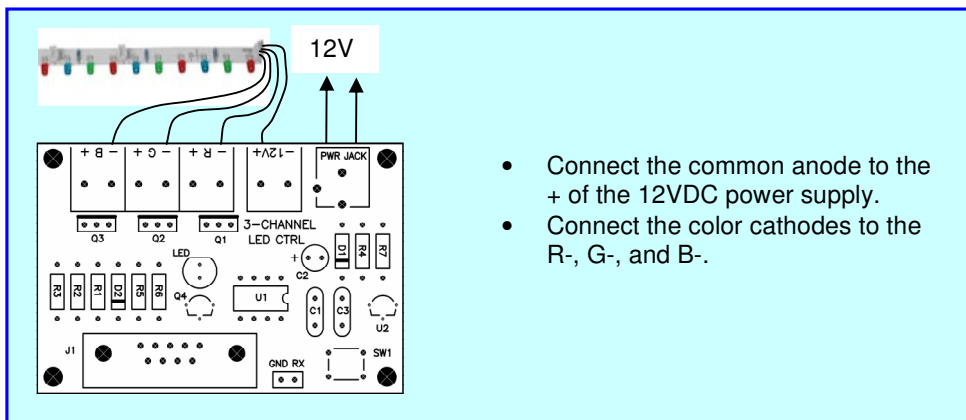

DIY K191: 3-Channel RGB LED Controller

2.2 Incandescent (12V) light bulb connection.

- Connect the bulbs to the outputs R, G, B (polarity is not important).

2.3 LED connection.

- Each LED requires a series current limiting resistor – 680R supplied
- Connect LED anode to the R+, G+, and B+.

2.4 Common anode RGB LED connection.

- RGB LEDs require 3 x series current limiting resistors – 680R supplied.
- Connect LED anode to +, cathodes to R-, G- and B- .

DIY K191: 3-Channel RGB LED Controller

2.5 Module connection to a microcontroller (Serial TTL interface).

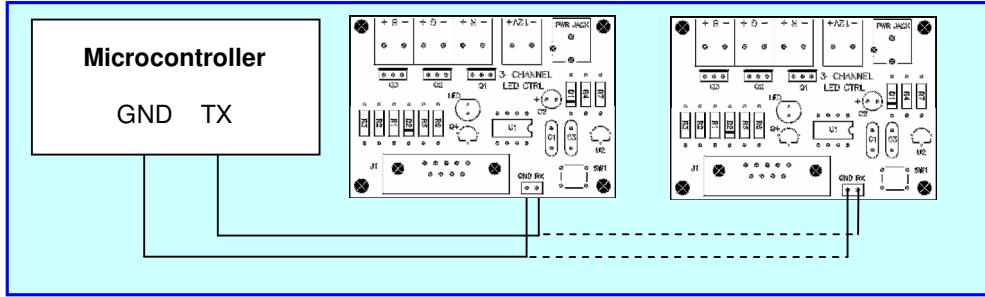

2.6 Module connection to a computer serial port.

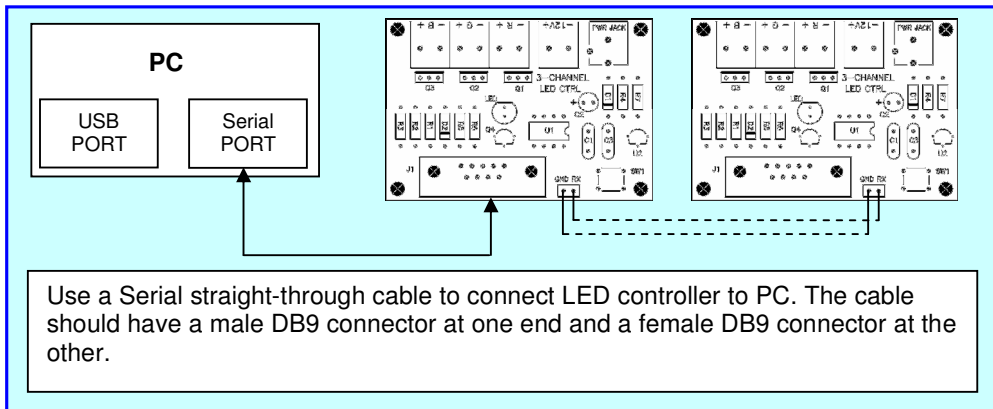

2.7 Module connection to a computer USB port.

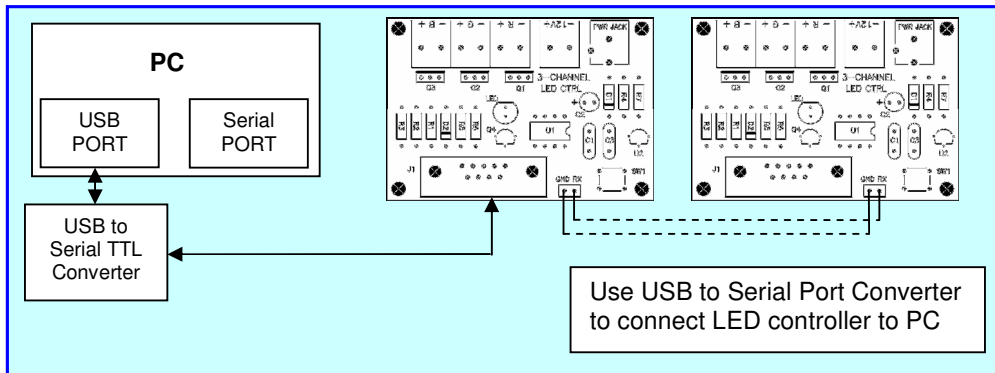

2.8 Preprogrammed Sequences.

The module includes 6 preprogrammed light sequences with smooth fade effects and hard transition effects. Press a button to switch the light sequences. The last selected sequence is saved in memory.

Sequence 1 - the channel light intensity increases and decreases synchronously for all channels.

Sequence 2 - the channel 1 light intensity increases and stays at max value, next the channel 2 light intensity increases. Then the channel 3 light intensity increases.

Sequence 3 - the channel light intensity increases and decreases with the shift for each channel.

DIY K191: 3-Channel RGB LED Controller

Sequence 4 – sequenced colors: red – green – blue with hard transition effects.

Sequence 5 – random colors with hard transition effects.

Sequence 6 – strobe effect: all outputs blink with 50% duty cycle.

3 Commands.

3.1 Command Format.

The module is controlled using a simple command set. The character decimal 254 (0xFE) is a command prefix. All commands start with 0xFE and a device address byte. Then a one command code byte followed by the parameters.

Command Syntax: 0xFE [device address byte] [command byte] [parameter]

Command Summary

Prefix	Command	Parameter	Description
0xFE	0x41	1 byte	Set the module address
0xFE	0x42	2 bytes	Set the channel intensity level
0xFE	0x43	1 byte	Start Sequence
0xFE	0x4C	61 bytes	Download the custom sequence
0xFE	0x52	1 byte	Set the intensity level for all channels
0xFE	0x54	1 byte	Set sequence time

3.2 Command Description.

For complete command description please download expanded documentation from www.kitsrus.com/pdf/k191exp.pdf.

4 Windows software.

The Windows software provides module control from PC and is used to create custom user-editable sequences. Use a USB to Serial Converter **or** Serial straight-through 9-way cable to connect the LED controller to a PC.

The Windows software can be downloaded from "www.kitsrus.com/zip/k191.zip"

Fig.1

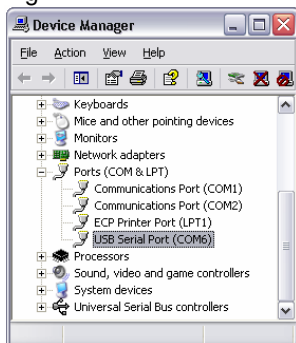

No installation is required. Copy the LEDControl.exe and IniDat.ini files on your disk and double-click on LEDControl.exe to run the program.

DIY K191: 3-Channel RGB LED Controller

4.1 Interface description.

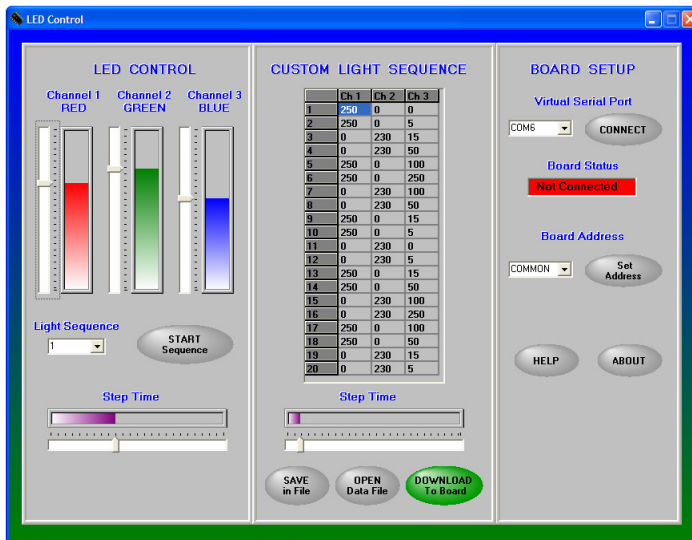

The program graphical interface includes the 3 sections:

1. LED Control
2. Custom Light Sequence
3. Board Setup

LED Control section includes the tools to set the light intensity for the each channel. When you move the slide bar the program send the commands to set the channel intensity level. Also, you can select and start the preprogrammed sequence and set sequence time.

Custom Light Sequence section provides the tools to create the custom sequence. The section includes a table with the 3 columns. The first column includes the intensity data for the channel 1, the second column – for the channel 2 and last column – for the channel 3. The each column includes 20 points (cells) to hold channel intensity data.

To create the custom sequence enter data in cells (like in Excel Spreadsheet). Move the slide bar to set the step time between points and click “Download to Board” button. The program will send custom sequence data to board and start the custom sequence automatically.

Click “Save to file” button to save custom sequence data. The program will open the Save Dialog form. Enter the file name and click OK button to save data in file.

You can also read custom sequence data from the file. Click “Open Data File” button and select the file. The program will read data and fill the table cells automatically.

Board Setup section provides the tools to select the virtual serial port, display the board connection status and set the board address.

If you run the program first time select the Virtual Serial Port number and click CONNECT button. Check the board connection with the board status indicator.

The board address provides the opportunity to connect the multiple boards with the independent control for each board. The address range is 0x4C – 0x5A. Default module address is 0x4C. The address 0x00 is a common address for all modules. The module address is stored in internal module EEPROM.

To set the board address select the address from drop-down box and click Set Address button. The program will send a command to set the board address.

5 Kit Assembly.

Before starting, check the components supplied in the kit against the parts list.

It is recommended that components be soldered in following order:

1. Resistors R1 ... R7.
2. Diodes D1 and D2.

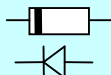

Match up the bar on the diode D1 with the diode image on the overlay.

DIY K191: 3-Channel RGB LED Controller

3. Capacitors C1, C3 (polarity is not important).
4. U1 socket.
5. 78L05 voltage regulator.
6. Transistor Q4.
7. Capacitor C2.

C2 – Electrolytic capacitor is polarized. The positive lead is marked on the overlay, the negative is marked on the body of the capacitor.

8. Tactile switch.
9. LED.
10. MOSFETs.

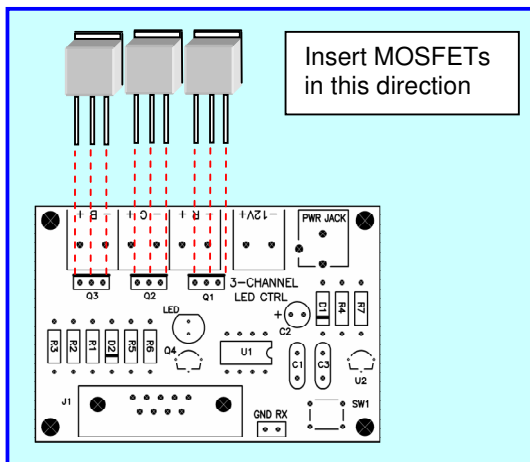

11. Power and LEDs connectors.
12. Header J2.
13. DB9 connector.

Pre-test. Do not insert the microcontroller chip into socket yet. Connect a 12VDC supply to power connector and measure the voltage across pin V and ground pin of the serial interface connector J1. If this voltage is approximately 5 volts, **remove power** and insert the microcontroller chip U1.

Three LEDs, 1 x red, 1 x green and 1 x blue, together with 3 x 680R current limiting resistors have been included with the kit. These components can be connected to the controller for testing. The microcontroller chip includes a test program that flashes each LED in turn.

First connect all the LEDs and resistors to module according to Fig 2.3. Connect the power supply and turn on – each LED will flash in turn.

- Never short the module outputs.
- Do not connect LEDs if power supply is connected to module.

Technical Support. Contact the kit developer by email to 'polar@BasicISP.net'

DIY K191: 3-Channel RGB LED Controller

5.1 Parts List.

Ref Des	Qty	Type
Capacitors		
C1	1	0.33uF ceramic
C2	1	10uF 16V electrolytic
C3	1	0.1uF ceramic
Resistors		
R1, R2, R3, R7	4	470R 0.25W carbon film
R4, R5	2	5.1K 0.25W carbon film
R6	1	10K 0.25W carbon film
Resistors for testing	3	680R 0.25W carbon film
Semiconductors		
D1, D2	2	1N4148 diode
U1	1	CY8C24124A-24PXI MCU
U2	1	78L05, 5V regulator
Q1, Q2, Q3	3	FDU8782 n-channel MOSFET
Q4	1	2N3904 transistor
Miscellaneous		
IC socket, 8 pin	1	Socket for U1
PWR,R,G,B	4	Terminal block, 2 pin, 5.08mm step
J1	1	DB9 female connector
J2	1	Header 2 pin
PWR JACK	1	Power jack, 2.5mm central positive pin
SW1	1	Tactile switch
LED1	1	LED 5mm
LEDs for testing	3	5mm - 1 x Red, 1 x Green, 1 x Blue

5.2 PCB.

