

DIY Kit 127. 3 1/2 Digit LCD Digital Panel Meter

The 7106 chip is one of the long term survivors in the IC world. It was launched in 1977 yet it has remained as popular as ever.

The reason is that it contains in it all the active circuitry for a 3 1/2 digit panel meter (DPM) in a single chip. It was designed to interface directly to a liquid crystal display (LCD). (It has a sister chip, the 7107, intended for connection to light emitting diode displays.) So the chip contains BCD to seven segment decoders, display drivers, clock and a reference voltage as well as the necessary analog to digital (a/d) circuitry to convert the input voltage to a digital form. The a/d system also indicates the polarity of the input voltage.

Voltage is the most frequently measured electrical quantity. In temperature meters, current meters, wind speed meters and resistance meters what is actually being measured is voltage, or more correctly, the potential difference between two points. After calibrating the meter for its particular purpose then the potential difference measured will give an accurate digital reading of the analog quantity being measured.

With a few additional external passive components the 7106 chip may be made into an easy to use meter for any of these purposes especially multiple range digital volt meters.

Digital meters have many advantages over analog meters that use a pointer and moving coil.

1. They are easier to read. In the majority of applications it is better that the value displayed is exactly the value being measured, for example, 13.6V. To use an analog display with its many graduated scales (some going up and others going down) and switches requires considerable practice. But a simple LCD which reads '13.6' can be understood by everyone.
2. DPMs built using the 7106 are physically stronger and more robust than analog meters because they have no moving parts.
3. The 7106 by its very nature can be adapted to so many uses at such a low cost that it has actually created markets for itself.

All of these factors add up to a better, cheaper product which everyone can afford.

In this Kit we have supplied the 7106, the LCD and the essential components and information necessary for you to custom build it into a panel meter of your choice. The PCB has a printed overlay on it so that the position of all the components is clearly indicated and construction only takes a few minutes.

The kit is constructed on a double-sided, through hole plated printed circuit board (PCB). Protel Autotrax and Schematic were used to design it.

ASSEMBLY INSTRUCTIONS

Assembly is generally straightforward. Follow the overlay to tell you where to put the components. Leave resistors RA and RB until last.

Start by inserting all the resistors first, followed by the capacitors. Capacitors C1, C4 and C5 are mounted under the IC so make sure they are pushed down close to the PCB. Next comes the 40 pin IC socket for the 7106. Once again be sure it is pushed right down before soldering.

The LCD is mounted on **two** 20 pin socket strips. These are made by cutting apart a 40 pin IC socket using your side cutters. This allows the LCD to sit above the 7106 chip. Take care that these strips are at right angles to the PCB otherwise inserting the LCD will be difficult.

Trimpot P1 can be fitted to either side of the PCB. Putting it on the rear (solder side) of the PCB makes it easier to adjust if the meter is mounted on a panel.

Lastly insert the 7106 into its socket, followed by the LCD. Make sure you get them round the correct way. A small triangle on the overlay marks pin 1 of each part.

All that remains is to determine the values of RA and RB (described later) and soldering them in, along with a link for the decimal point position if required. For the moment just solder a link for RB.

CALIBRATION

Connect 9V to the kit. All that remains is calibration. This is easy. Connect a multimeter between pins 35 and 36 of the 7106. Use alligator clips on the solder side of the board. Use trimpot P1 to adjusted VREF measured between these pins to 100mV.

(You can also do this another way by applying a known voltage to the input terminals and adjusting VREF for the this reading so that $V_{IN} = 2 \times V_{REF}$. This requires that RA and RB are installed.)

Now decide the input voltage range you want to measure according to the table on the next page.

WHAT TO DO IF IT DOES NOT WORK

Poor soldering is the most likely reason. Check all solder joints carefully under a good light. Check that all components are in their correct position on the PCB.

Are the IC and LCD in the correct way. Check no pins are bent up. This is very easy to do with a 40 pin IC and the LCD display.

Is the battery flat?

CIRCUIT DESCRIPTION

The heart of the meter is the A/D converter built into the 7106. It uses a dual slope conversion technique. It relies on the charging and discharging of an integrating capacitor and having a counter count when the capacitor voltage is above a set value. Since the capacitor discharge

DIY Kit 127. 3 1/2 Digit LCD Digital Panel Meter

is linear the counter reading is proportional to the input voltage. There are three phases to the process:

Phase 1 - Auto Zero.

The auto zero capacitor is charged to the integrator's offset voltage. This voltage is subtracted from the input signal during phase 2. The integrator thus appears to have zero offset voltage.

Phase 2 - Signal Integrate.

The signal input is averaged for 1000 clock pulses.

Phase 3 - Reference Integrate.

VREF is averaged back to zero volts. The number of clock pulses counted to return to zero is a digital measure of VIN.

The Reference Voltage supplied to the 7106 at pins 35 and 36 should be between 100mV and 1V for most purposes. This corresponds to a full scale reading of 199.9mV and 1.999V respectively. **In this kit VREF is set to 100mV but is adjustable from 89 - 107mV.**

Let us discuss parts of the circuit in more detail and investigate how to customize the meter for your purpose.

Decimal Point. A jumper selects the decimal point position in the LCD. Displays are driven by applying a symmetrical square wave to the back plane (BP.) To turn on a segment a waveform 180° out of phase with the BP (but of equal amplitude) is applied to that segment. To get the decimal point the external circuit inverts the BP output (pin 21) with a transistor and applies it to the required decimal via a jumper. Pin 37 is used as the negative supply for these externally generated segment drivers.

Analog Section. C1 is the reference capacitor and is unchanged for all ranges measured. INLO is tied to the analog COMMON pin 32.

The integration capacitor C5 is suitable for VREF values but the value of the integration resistor R1 should be increased to 470K for a VREF of 1V.

System Timing. This is determined by the components connected to pins 38, 39 & 40. Values are unchanged for all ranges measured. The internal oscillator runs at 48kHz, or 3 readings per second.

Auto-Zero Capacitor. This is C4 connected to pin 29. It has some influence on the noise of the system and recovery from overload input. For 200mV full scale a 0.47uF capacitor is recommended.

Reference Voltage. The analog input required to generate a full scale output of 2000 counts is

$$V_{IN} = 2 \times V_{REF}$$

Thus to set the meter to read from 0 - 199.9mV VREF is set to 100.0mV.

VREF is measured between pins 35 & 36. The trimpot, P1, is adjusted to get the correct reference voltage.

To measure voltage greater than 200mV an input voltage divider is required (see Figure 4). The general relation for full scale sensitivity is now:

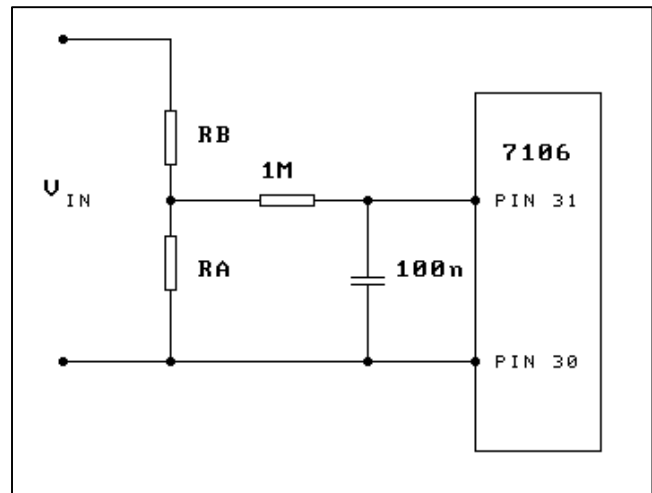

$$V_{IN} (\text{full scale}) = 2 \times V_{REF} \times R_A / (R_A + R_B)$$

Figure 4. Input Attenuation for VIN > 200mV

For example, a 0 - 20V range can be obtained using a 100:1 voltage divider. This can be done by making RA = 300K and RB = 2.7M. The decimal point jumper is placed at position '2' so a full scale display of 19.99V is available. The following table shows the resistor values to use for different voltage ranges and the position of the decimal point jumper.

Range	RA	RB	DP jumper
200mV	10M	Wire Link	2
2V	300K	2.7M	4
20V	100K	10M	3
200V	10K	10M	2

Note: For the 20V and 200V range RB should be 9.9M and 9.99M respectively. This introduces a slight error that can be corrected by adjusting VREF slightly (CALIBRATION method 2).

The 200mV range does not require a voltage divider on the input but a 10M resistor is used for RA anyway. The input resistance of the 7106 is so high that this resistor is necessary to short out any static charge accumulating on the input terminals.

DIY Kit 127. 3 1/2 Digit LCD Digital Panel Meter

Putting this all together we can construct a multi range voltmeter as shown in Figure 5.

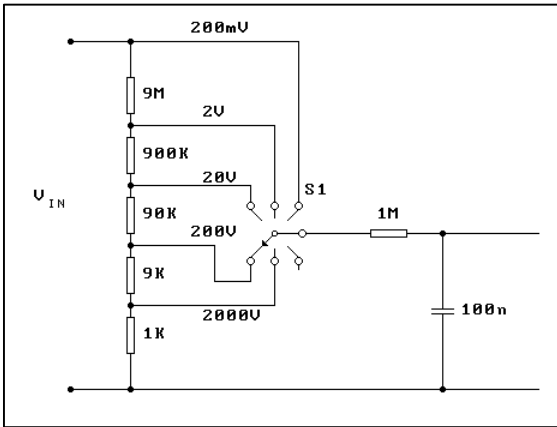

Figure 5. Multi range Voltmeter

Non-standard Voltage Input. In many applications it is required that the output of a transducer is converted by a scale factor into some meaningful result. For example, a load cell of a weighing system may have an output voltage of 0.682V when it has 2.0 Kg weight on it. You want the meter to read the range 0 - 1.99 Kg directly.

Set the meter (RA and RB) to have a 2V input range. This gives a maximum input voltage of 68.2mV. Then adjust VREF to 34.1mV (half the input voltage), put the decimal point in the correct position by moving the jumper and the panel meter now reads off 0 - 1.99 Kg directly from the display.

Voltages Below 200mV. On the 200mV scale the least significant digit represents 100 micro volts. To resolve smaller signals it is necessary to use an op-amp prior to the voltage input to amplify the DC voltage.

Current Measurement. The current must be converted into a voltage using a shunt resistor. The voltage divider resistors RA and RB are not used. The principal is shown in Figure 6.

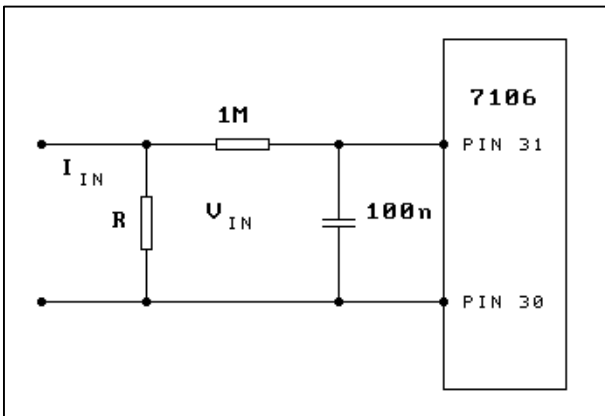

Figure 6. Principle of Current Measurement

If $R = 0.1$ ohms then 200mV will be developed when the current through it is 2A. This voltage is applied to the meter which is set up for the 200mV range. Power dissipation at the maximum reading is I^2R .

To measure a full scale of 200mA then R should be 1.0 ohms in order to generate 200mV input to the meter. For a 20 mA meter then $R = 10$ ohms.

A general multi range current meter is shown in Fig. 7.

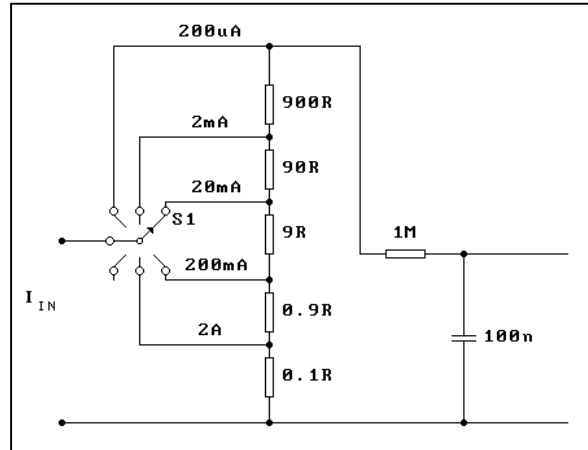

Figure 7. Multi range Current Meter

Resistance Measurement. The kit is not specifically designed for this purpose, however, with some changes to the board this function can be carried out. The principle is shown in Fig. 8. The unknown resistance is put in series with a known resistance and a current is passed through the pair as shown. If they are of equal value the integration and de-integration ramps will be of equal slope and the display will read 1000. The maximum readable ratio is 1.999. Since a ratio is being measured the reference resistor need not be exact.

$$\text{Displayed reading} = R_{\text{unknown}} / R_{\text{standard}} \times 1000$$

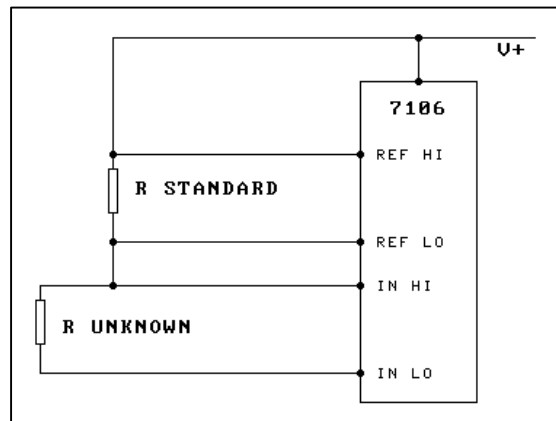

Figure 8. Measuring Resistance

DIY Kit 127. 3 1/2 Digit LCD Digital Panel Meter

WHAT TO LEARN FROM THIS KIT

The Kit shows how much of electronics today can be contained in a single chip. Commercial low to medium cost digital multimeters are nothing more than this kit, some switches and passive components and a plastic case. The main reason today for the failure of meters is more likely due to switch contact and mechanical failure rather than failure of the electronics itself.

Web Address & Email

You can email us at peter@kitsrus.com if you have any problems or requests. See our Web page at:

<http://www.kitsrus.com>

The data sheet for the 7106 may be downloaded from the Intersil website at

www.intersil.com

or you can get it from our website at

www.kitsrus.com/pdf/7106.pdf

You can get the pinout information for the LCD at

www.kitsrus.com/pdf/vi302_dp.pdf

You may get a detailed Application Note for the 7106 at

www.kitsrus.com/pdf/7106_an1.pdf

PARTS LIST – K127

Resistors (0.25W carbon)

820 grey red brown.....	R3	1
27K red violet orange	R2,5,6.....	3
47K yellow violet orange ...	R1	1
100K brown black yellow..	R4	1
1M brown black green.....	R7	1

Capacitors

100pF 101 ceramic	C3	1
100nF 104 monobloc.....	C1,2	2
220nF 224 monobloc.....	C5	1
470nF 474 monobloc.....	C4	1

Semiconductors

BC547, NPN transistor.....	Q1	1
7106 IC.....	IC1	1
3 1/2Digit LCD A/D converter		

Miscellaneous

Trimpot, 200Ω.....	P1	1
Liquid Crystal Display.....	LCD.....	1
3 1/2digit, VI-302-DP-RC		
IC socket, 40 pin.....	2
For mounting IC1 and LCD		
9V battery snap.....	1
PCB, K127	1

