

# KIT 81. 16F/C84 PIC PROGRAMMER

The 16F84 micro-controller uC from Microchip technologies (formerly the 16C84 which is now discontinued) has become the point of entry into the field for many beginners & hobbyists. This is because the cost of the tools needed to support the device are very low and the device itself is easier to use than other uC's on the market. The main feature is that it does not require a UV light to erase the program inside it. The stored program is electrically erasable in seconds. It can be used over & over.

This development programmer - hardware & software - is designed only for the 16F84. This eliminates many sources of confusion for the first time user. Software for the now discontinued, but still available PIC16C84 is also provided with this kit. When we say 16F84 below we also mean the 16C84. The small differences between the two versions are explained at the end of this document.

All the software & hardware to build & run your first 16F84 program are contained in this kit. A 16F84-04/P uC comes with the kit. A program and components to flash an LED comes with the Kit.

This Kit was originally published in *Electronics Australia* in 11/95 & 4/96. These articles are reprinted here. They should be read first then read the modifications & additions as outlined below. Only after you have read all the documentation should you start construction.

## FEATURES

- device is EEPROM. You can use the 16F84 over & over without the need to use a UV eraser
- software is only for the PIC16F84 so no other programming options to confuse you
- software can verify, erase & read as well as load. Program & EEPROM spaces can be treated separately
- configuration fuses can be read, loaded & verified separately
- programmer test option in software
- INHX8M object file format also supported
- introductory manual plus supplied on disk
- powered by a DC plug pack 9-12V unregulated, center positive.
- test program *lights* provided to immediately test your programmer

## SOFTWARE

The read.me file on the floppy disk gives a description of the software which comes with this Kit. In addition to the assembler & the programmer there are also the Microchip data sheets on the 16C/F8x. A program to test the

programmer is also included. (The LED & resistors needed are included with the kit. All you will need is a breadboard to plug them in and a battery.) This program, *lights*, uses the WDT timer to flash an LED. So for this example changing the RC values has no effect on the flash rate.

## ASSEMBLY

First check the components supplied in the Kit against the Component listing printed on the next page. Identify all the components. It is generally best to solder the lowest height components first: the resistors, diodes & IC sockets. Make sure to get the diodes the correct way around. Match up the bar on the diodes with the bar on the overlay. There is one link to add to the board. Note that two of the 0.1uF monoblok capacitors fit within the IC sockets.

Check the orientation and name of every IC before you put it into its socket. Match the dimple on the overlay with the dimple on the IC. Use a 9V - 12V plug pack center positive, to run the programmer. It will also run off a 9V battery

## CIRCUIT DESCRIPTION

This is described in the documentation. For a more detailed specification about the programming sequence see AN589 in the Microchip Embedded Controller Handbook. (This Application Note is not fully available on the Microchip web site.)

**Schematic.** The schematic for the programmer is given on the back page of the magazine reprint. Some changes have been made to the original schematic: 78Lxx are used instead of 78xx; power input jack added, 10K resistor network added.

The circuit is described in the magazine articles and in more detail in manual.doc on the floppy disk. It is in Word 6 format. You should print this out in full. To test the programmer enter 'P84 /T' (with no 16C/F84 in the socket) & cycle through the tests by pressing the spacebar. Sixteen tests are done then 'Automatic input tested passed' will come up if everything is OK. Run the programmer under DOS, not under Windows.

## WHAT TO DO IF IT DOES NOT WORK

Check that all components are in their correct place and the correct way around. Check the soldering. Check the voltage levels around the circuit as described in the documentation. Check the six cable connections. Is there a short circuit in the connector? Are the leads going to the correct pins from the PCB.

## REFERENCES

The Internet is the place to get References, data sheets and any sort of technical support.

Microchip's web page is at  
<http://www.microchip.com>

# KIT 81. 16F/C84 PIC PROGRAMMER

Download the 16F84 data sheet from here. Or you can download from the Microchip ftp site at

<ftp://ftp.futureone.com/pub/microchip/download>

30430c.pdf is the data sheet index number for the 16F84.

Some excellent web sites related to PIC's are:

<http://www.geocities.com/SiliconValley/2499>

<http://www.geocities.com/SiliconValley/WAY/5897/> Microchip Net Resources

<http://dontronics.com> Many PIC links and up to date PIC information here. PIC programmers.

<http://www.execpc.com/~rdmiller/gnupic>

The following books are well worth getting particularly since they have been revised to include the 16F84:

**Easy PIC'n, PIC'n Up The Pace & PICn Techniques** published by Square One Electronics.

See <http://www.sq-1.com>

**Programming and Customizing the PIC Microcontroller** by Mike Predko.

See <http://www.myke.com>

**PIC Newsgroup.** There is an active & helpful PIC newsgroup ideal for beginners: no question is judged too stupid. To subscribe send email to listserv@mitvma.mit.edu with the message SUB PICLISTDIGEST in the body of the message. You will receive an email back within minutes usually confirming that your registration was successful then you will start to receive a single message once a day containing all the messages sent to the list for the previous day. Read the messages for a week or so to get the feel of the newsgroup before asking questions yourself. Note that this is a subscribed newsgroup. It is not a Usenet newsgroup. It is relatively free of the spams, bad manners and off-topic items which plague the normal Usenet newsgroups.

**Software Difference Between C & F Versions.** The simple answer for the beginner is that there is no difference. When you have done some programming for a while you will find there is one difference which is in the configuration word. It is in the **Power Up Timer Enable Bit**. This bit has reversed its meaning. In the F you must write a 0 to enable the timer while for the C you had to write a 1. You will see this in the program examples. In *lights.pct* the config word changes from 0ffh in the C version to 0f7h for the F version. So long as you set it to 0 in the config word it will be enabled. Remember bits left unprogrammed in the config word are read as 1.

There are two other hardware changes in the code protection bits (8 to 13) and the RAM file registers (increased from 36 bytes to 68 bytes.) Code protection will not normally be used by beginners.

## COMPONENTS

Resistors 1/W 5%:

1K brown black red	R1 R8	3
3K3 orange orange red	R3 R6	2
3K9 orange white red		1
10K brown black orange	R2 R4 R5 R7	4
10K 3R4P resistor network		1
22pF ceramic capacitor		1
DB25 25 pin right-angle, pcb-mounted connector		1
100uF/25V ecap	C4 C5 C7	3
10uF/25V ecap	C2 C3	2
BC557	Q1 Q2	2
1N4004 diode	D1 - D5	5
1N4148 diode	D6 D7	2
0.1uF 104 monoblok	C1 C6 C8 C9	4
3mm led	D8	2
LM/NE555	IC1	1
78L12 voltage regulator	IC2	1
78L05 voltage regulator	IC4	1
PIC16F84-4/P		1
DM7407N	IC3	1
8 pin IC socket		1
14 pin IC socket		1
18 pin IC socket		1
DC power jack		1
Kit 81 pcb		1
Floppy disk		1

Note that one LED, the 22pF capacitor, the 1K & 3K9 resistors are supplied to test your first program, *lights*, on a breadboard.

This programmer design is a so-called 'David Tait' based design. It will work with a wide range of freely available software. All that will need changing is the configuration file and the hardware file depending on whether you use a 7406 or 7407. See [dontronics.com](http://dontronics.com) for the Nigel Goodwin & the P16PRO software and further references.

Documentation revised october 25, 1998. On-board DB25 added january, 1999. Assembler & programmer software just for the 16F84 added 3/99. P16PRO Light software added 6/99. Extra page of documentation added below 11/99.

-----

# KIT 81. 16F/C84 PIC PROGRAMMER

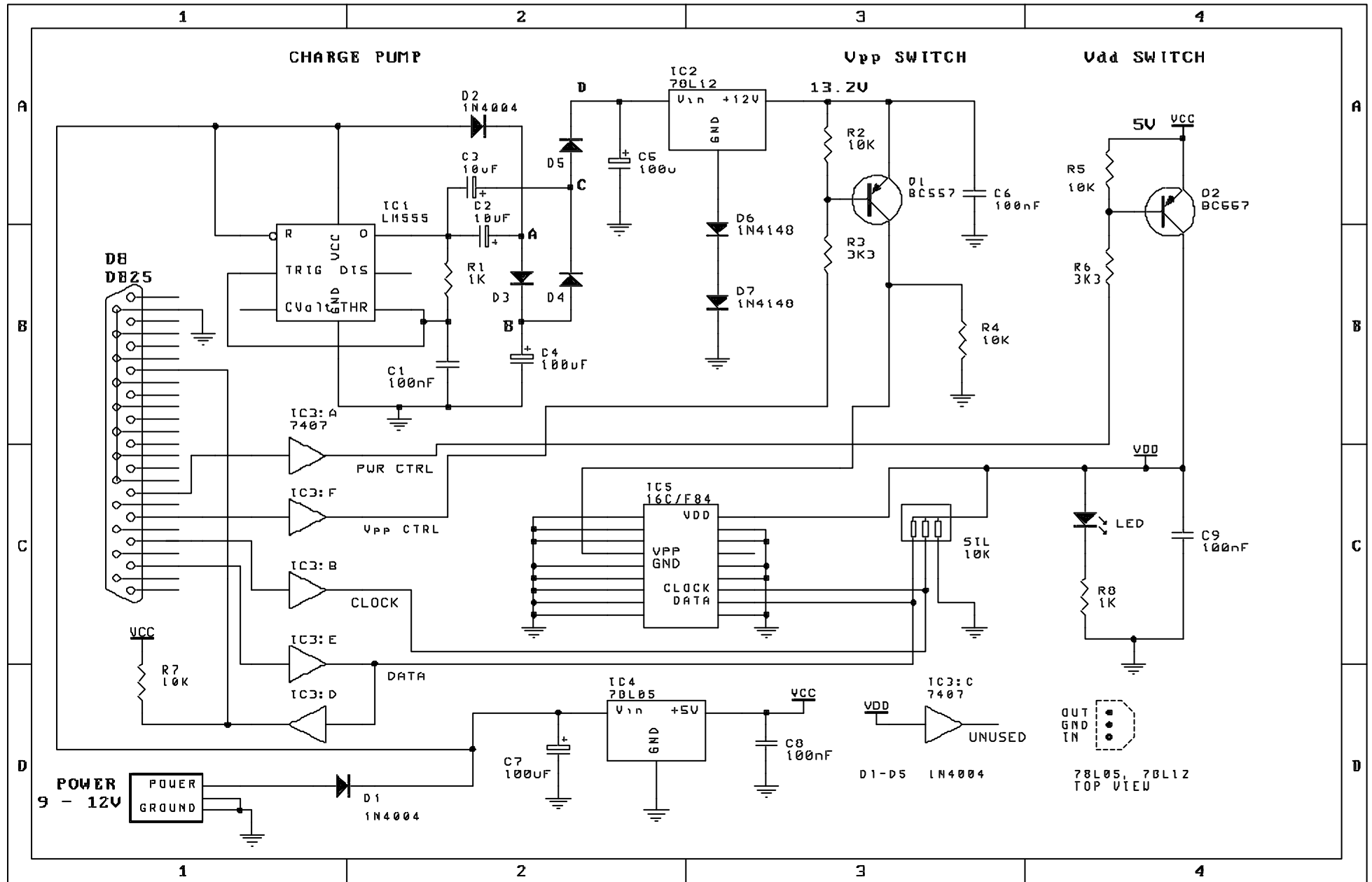

# KIT 81. 16F/C84 PIC PROGRAMMER

Note of additional explanations added november, 5, 1999.

The 16C84 is almost gone now. It has been replaced by the 16F84. Assemblers and programming software to use the 16C84 is included on the floppy disk. But the following discussion will refer to the 16F84. (If you are using a 16C84 just use the appropriate programs as supplied here.)

After construction of the hardware run 'pf84 /t' from a MS-DOS window. Do not have a PIC chip in the socket. This test will tell you if the hardware is OK.

## Program assembly

Assemble the 'lights.pic' program supplied by typing

```
af84 /hex lights.pic lights.hex
```

A summary of the assembly process will be printed on the screen. Always use the /hex option. Remember you should be in a MS-DOS box.

## Programming the 16F84

Put the chip into the hardware.

```
Type  
pf84
```

You should see a list of the options.

```
Type  
pf84 /hex /e
```

That should erase the chip. You can change the parallel port if you are not on LPT1 by adding the option /p2 to the command line.

```
Now type  
pf84 /hex /la lights.hex
```

It may program OK. Or it may error.

If it gives an error then this shows you how software which is not fully supported can become out-of-date as computers get faster and different.

## P16PRO Light

We have supplied another program program on the disk. This is a freeware version of P16PRO which is used in my general PIC Programmers Kits 96 and 119. You may also download the latest version from

**[www.geocities.com/SiliconValley/Peaks/9620](http://www.geocities.com/SiliconValley/Peaks/9620)**

This software is fully supported. The author Bojan Dobaj can be easily contacted by email if you have any problems.

Anyway extract p16pro1.zip in a folder. Then do two renaming of files to match the hardware of it 81 to Bojans program.

Rename p16pro1.ini to p16pro1.old.

Rename kit81.ini to p16pro1.ini  
Then run p16pro1.exe

```
Type F1 to open the program (lights.hex)  
Alt - S - D and enter 1 for the 16F84  
Do F7 to blank check  
If not blank hit F9. That should erase and blank check.  
Hit F4 to program.  
Hit F5 to verify again.
```

I have never had any complaints that P16PRO Light fails to program.

## Testing lights.hex

Use a breadboard to build the circuit shown in the *Electronics Australia* article, Fig 6, p78.

## Future Modifications

1. I am going to replace the rather complicated power supply on this Kit by the simpler power supply already used on Kits 96 and 119. A higher input voltage will be required: 17-30VDC or 13-20VAC.
2. I am going to put the test circuit for the lights.hex on the board so that you can immediately see that the programmer worked.

## Questions

If you have any comments, criticisms or questions you may contact me at

**[peter@kitsrus.com](mailto:peter@kitsrus.com)**

Note that the software supplied on the disk may also be downloaded from my website at

**<http://kitsrus.com/soft.html/k81disk.zip>**